

ACCUMULATOR SHUT-OFF VALVE

www.elwood.com

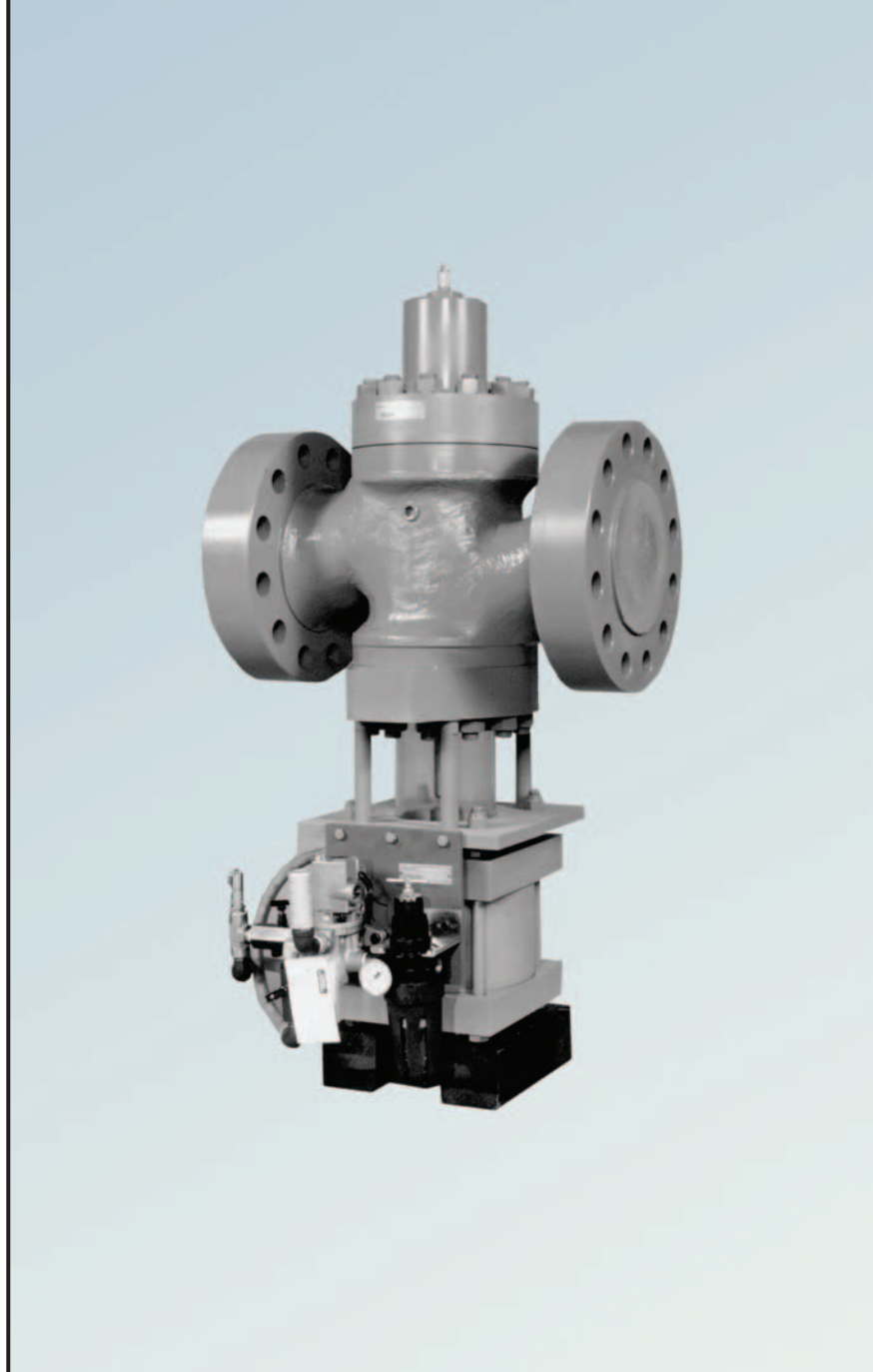

ISO 9001:2000
CERTIFIED COMPANY

Accumulator Shut-Off Valve

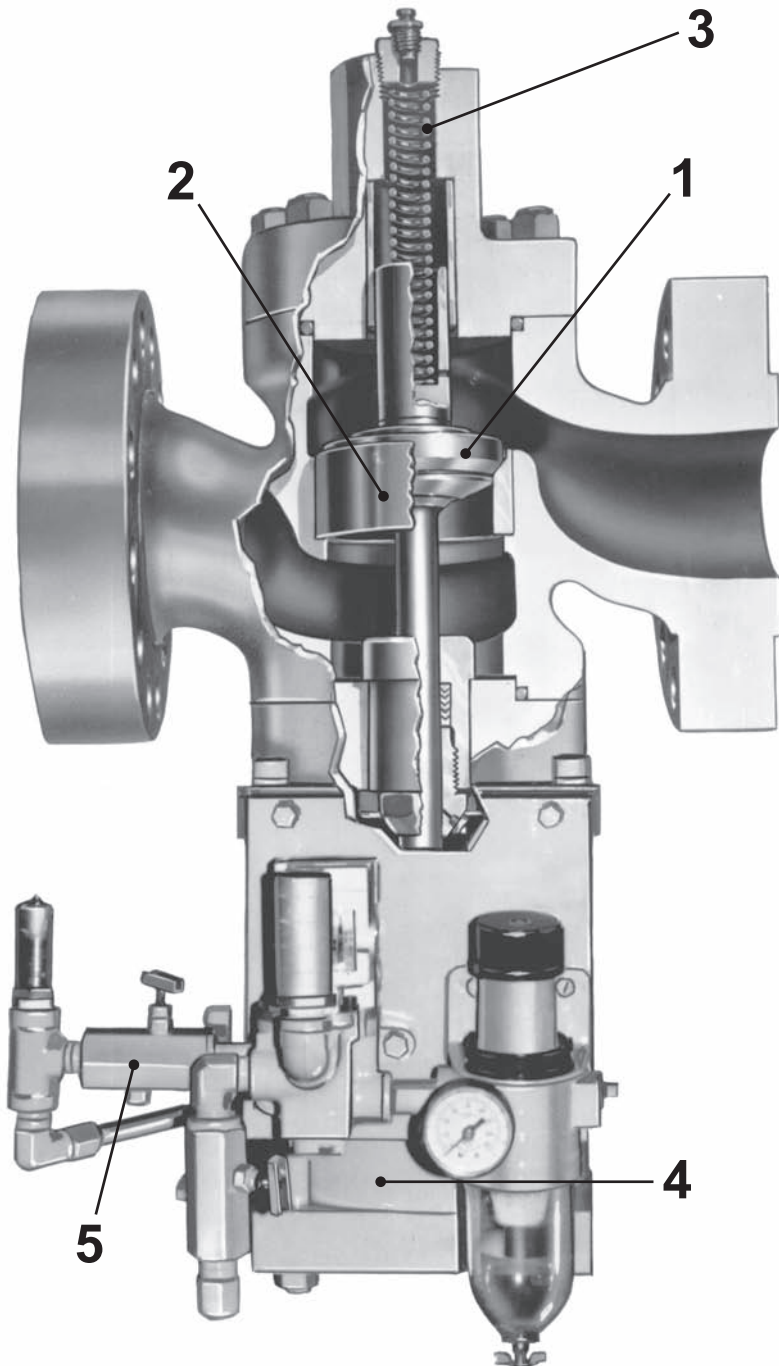

A stem-guided, stainless steel, poppet-type disc (Item 1) closes against the stainless steel seat (Item 2). Closing force is normally supplied by accumulator pressure acting on the valve disc; at very low accumulator pressure, such as is experienced when starting up, a stainless steel spring (Item 3) supplies sufficient pressure on the disc to ensure closure.

As the disc nears the seat on closing, a cushion is formed through control of the air flow out of the air cylinder (Item 4) by adjusting the speed control valve (Item 5). This cushion prevents damage to the valve when the pressure differential across the seat is great.

Once the valve has closed, air pressure to the cylinder alone will not open it. The pumps must be used to create pressure in the system equal to that in the accumulator. Only when this balanced condition exists can the valve be opened by pilot pressure. This prevents accidental opening of the valve, which could prove disastrous. As a final safety feature, only one static seal is exposed to accumulator pressure.

Elwood Shut-off Valve used in a Typical Accumulator System

No two installations need be exactly alike with regard to arrangement of pressure and liquid level devices. Elwood recommends, however, that both pressure and liquid method of control be used. A proper relationship of pressures and levels must be maintained at all times or complications will result. In the illustration at the right, one type of pressure sensing device and two types of level sensing devices are shown. The simplest combination involves float switches (A) and pressure control (B). The upper float switch opens on rising level to shut down pumps. The lower float switch opens on falling level to close the shut-off valve (C). The level control (D) will have sufficient switch contacts to load and unload the pumps, thus maintaining levels between normal low and normal high.

The level control (D) is, in effect, a level sensing device which receives its input signal from the height of the fluid in the bottle. A little more complicated than the float switch, it gives an output signal for all points of level within its range. This is necessary if remote indication or recording of level is required. Control of any components by means of switches can be arranged to suit the user's requirements.

Due to the fact that many variations and combinations of controls can be arranged, we suggest contacting the Elwood Engineering Department when a system is being planned.

Typical Installation of Elwood Accumulator System Shut-off Valve (A.S.S.O. Valve)

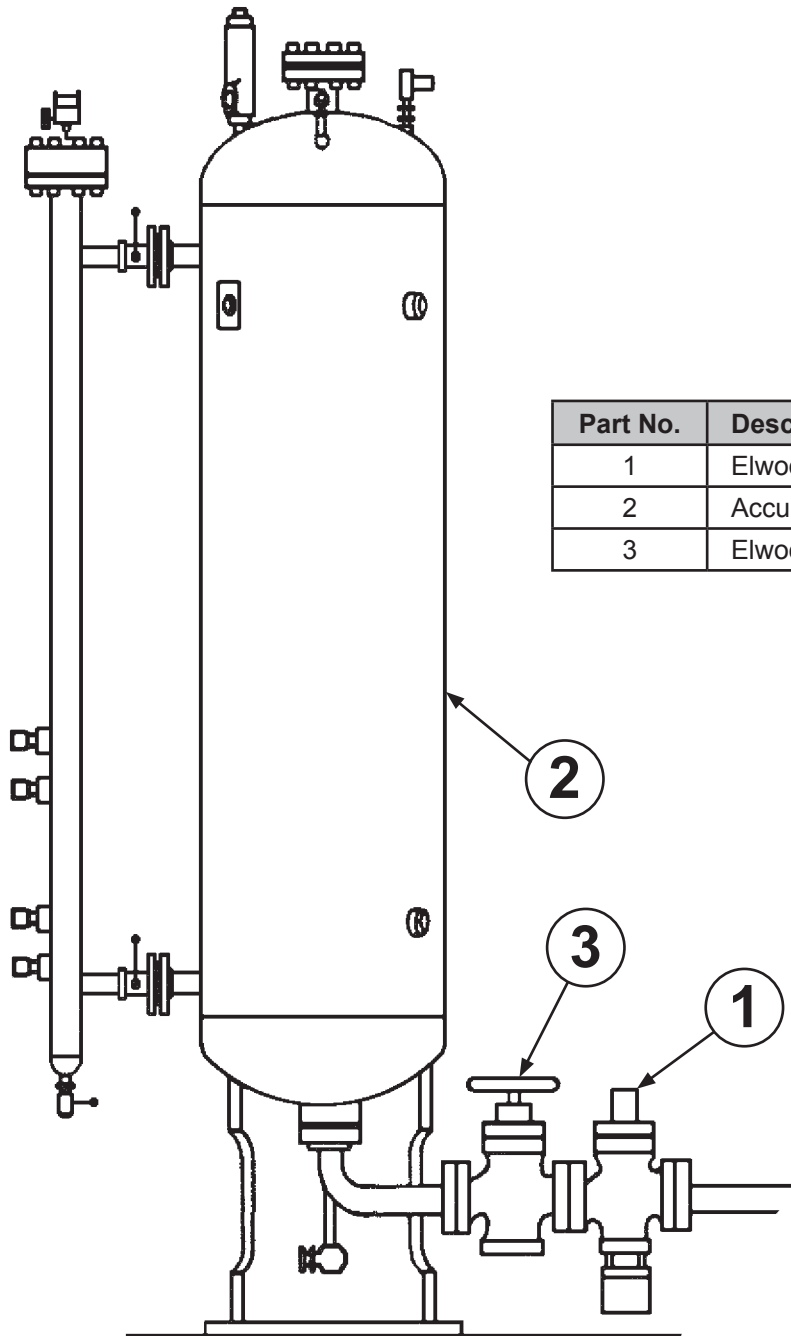

Part No.	Description
1	Elwood Accumulator System Shut-Off Valve
2	Accumulator Bottle
3	Elwood Shut-Off Valve

Dimensional Data

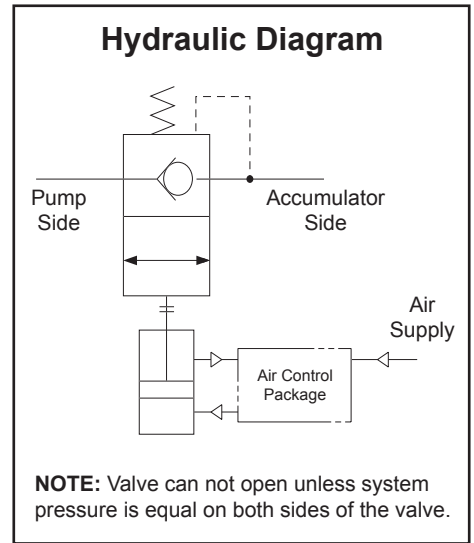
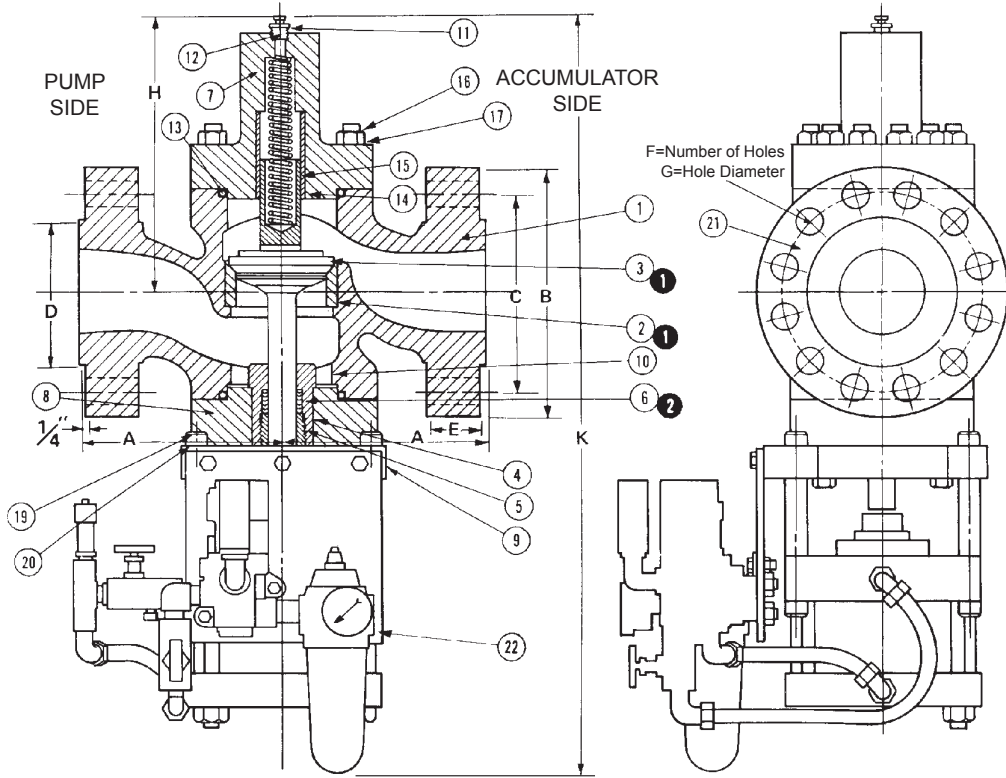

DIMENSIONS (ASA 1500 Flanges)								
SIZE	2	2-1/2"	2-1/2"	4"	6"	8"	10"	12"
A	4-1/2	5-1/4	7-1/2	9-3/8	12-1/4	16-3/8	17-1/2	23
B	8-1/2	9-5/8	10-1/2	12-1/4	15-1/2	19	23	26-1/2
C	6-1/2	7-1/2	8	9-1/2	12-1/2	15-1/2	19	23-1/2
D	3-5/8	4-1/8	5	6-3/16	8-1/2	10-5/8	12-3/4	15
E	1-1/2	1-5/8	1-7/8	2-1/8	3-1/4	3-5/8	4-1/4	4-7/8
F	8	8	8	8	12	12	12	16
G	1	1-1/8	1-1/4	1-3/8	1-1/2	1-3/4	2	2-1/8
H	10	11	9-7/8	11-3/4	17-1/4	15 / 21-3/8	17 / 29 *	16 / 28 *
K	28	29	33-7/16	38-1/4	50-1/2	*	57	57
C.V. Factor	49	57	87	120	375	46	990	1100
Valve Number	4702	4702.5	4703	4704	4706	660	4710	4712
Max. Flow GPM (LPM)	290 (1100)	390 (1480)	620 (2350)	950 (3600)	2500 (9500)	4708 (17,820)	6500 (24,600)	8000 (30,000)

3.5K models with ASA Series 1500 flange faces. 6K models with ASA Series 2500 flange faces available, consult factory.
 *Offset Accumulator / Pump side connection.
 All measurements in inches. Dimensions are subject to change without prior notice.

PARTS LIST			
No. Req'd.	Item No.	Name of Parts	Material
1	1	Body	Cast Steel
1	2	Seat	H. Stainless Steel
1	2	Disc	H. Stainless Steel
1	4	Stuffing box	Bronze
1	5	Gland	Bronze
1	6	Chevron Packing	Composition
1	7	Top Cap	Steel
1	8	Bottom Cap	Steel
1	9	Cylinder Plate	Steel
4	10	Spacers	Steel
1	11	Air Bleed	Stainless Steel
1	12	Reducing Bushing	Steel
2	13	"O" Ring	Composition
1	14	Bushing	Bronze
1	15	Spring	Stainless Steel
24	16	Stud	Steel
24	17	Hex Nut	Steel
4	18	Stop Nut	Steel
4	19	Bolt	Steel
4	20	Hex Nut	Steel
1	21	Taper Pipe Plug	Steel
1	22	Air Cylinder w/ Speed Control	

Refer to part numbers on nameplate when ordering parts.

Ordering Data - Accumulator Shut-Off Valve

MAXIMUM FLOW	
Size	Flow (GPM)
4702 - 2"	290
4702 - 2.5"	390
4703 - 3"	620
4704 - 4"	950
4706 - 6"	2500
4708 - 8"	4000
4710 - 10"	6500
4712 - 12"	8000

OPERATING PRESSURE	
2.5	2500 PSI (210 bar)
3.6	3600 PSI (250 bar)
4.5	4500 PSI (310 bar)
6.0	6000 PSI (415 bar)

ELECTRICAL REQUIREMENTS FOR AIR CONTROL PACKAGE		
Code No.	Voltage	Air Supply Connection Size
• 3	24 V D.C.	1/2" NPT
6	110 / 120 V - 50/60 Hz A.C.	
8	220 / 240 V - 50/60 Hz A.C.	

Other voltages available, consult factory.

PRESSURE RATING	
Code	Pressure
• 3.6K	3600 PSI (250 bar)
6K	6000 PSI (414 bar)

FLANGE STYLE	
• SR15	SR1500 Flange ◆
SR25	SR2500 Flange ◆
For Alternate Flanges Consult Factory	

VALVE ACCESSORIES	
Code	Description
58	Position Indicator
87	Complete Stainless Steel Valve

Inline flange orientation is standard. Consult factory for other types.

◆ ANSI 16.5 Series flange face is standard. Other types also available, please consult factory for details.

• **Standard:** Non-standard items available at extra cost.

Minimum air pressure requirement:
60 PSI (4 bar)

Maximum air pressure requirement:
120 PSI (8 bar)

4702 - 2" - 3.6K - SR15 - 2.5 - 3 - 58

Code No. Example:

Packed Spool Directional Control Valves

- Directional Valve for a range of applications
- Up to 46 GPM (32 GPM nominal)
- 3000 PSI (207 bar) and 6000 PSI (414 bar)

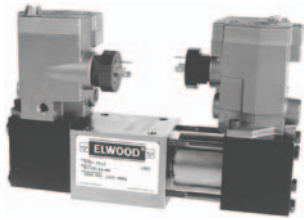

- Air Solenoid Operated
- 3-position spring centered
- 2-position spring offset
- 2-position momentary contact

Brochure 82

Poppet Type Directional Control Valves

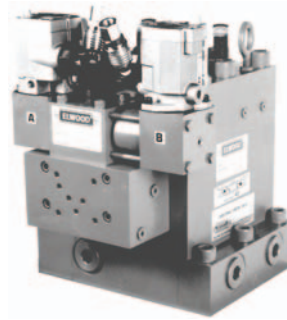

- Capacities to 1600 GPM (6057 LPM)
- 3000 PSI (207 bar), 4500 PSI (310 bar) and 6000 PSI (414 bar) models are available
- Built-in flow control
- Manifold mounted, NPT, socket weld or flanged

Brochure 395

Proportional Pressure Control System

Controlled Pressure Ranges:

390 PSI (27 bar) to 1500 PSI (103 bar)
 480 PSI (33 bar) to 3000 PSI (207 bar)
 580 PSI (40 bar) to 6000 PSI (414 bar)
 FLOW RATE: To 1000 GPM (3785 LPM)

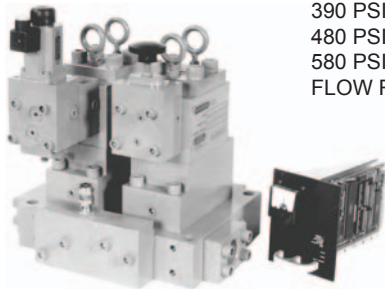

Brochure 104

Modular ISO-Lock

- Isolates manifold mounted directional control valves
- Reduces maintenance time - replace Directional Valves without depressurizing and draining hydraulic system
- Single lever operation to close all four ports (P, T, A, B). Cylinders can remain under the external load without having to be blocked
- Lockable per OSHA safety standard
- NFPA "DO"/CETOP and special mounting patterns available



Brochure 250

Descaling & Pump Unloading Valves

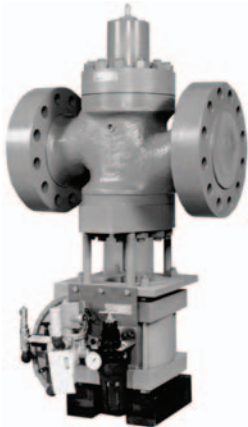

Capacities:

3000 PSI (207 bar)
 6000 PSI (414 bar)
 6000 GPM (22710 LPM)

Connection Sizes: 1-1/4" to 10"

Descaling Valves - Spindle – Brochure 2218
 DIN – Brochure 2219
 Pump Unloading Valves – Brochure 2213

Accumulator Systems

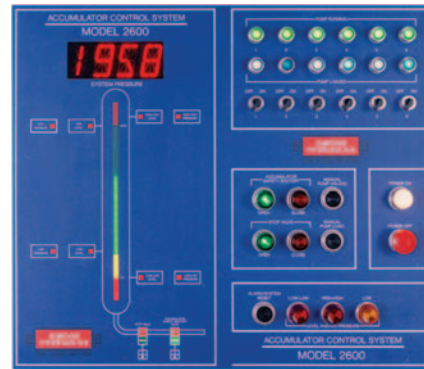

- Descaling
- Mill Systems
- Presses
- Controls
 - Level
 - Pressure
 - Pump Sequencing
 - Ballast Charging
- Designed to your specifications

Brochures 105, 380 & 102



ELWOOD CORPORATION

195 West Ryan Road • Oak Creek, Wisconsin 53154 • USA

Phone: 800-527-7500 • Fax: 414-764-4298

www.elwood.com

3/06 - Brochure 102

Rev. A