

## R Series Owner's Manual



LISTED  
For Industrial Control Applications  
File E37141

The R Series features a modulated LED infrared light beam highly immune to ambient light and direct sunlight. Retro-reflective, proximity and through-beam configurations are available. The basic ON/OFF function can be changed to time delay or other functions by merely inserting one of many plug-in cards available.

### Optional Plug-in Function Cards

MODEL	DESCRIPTION	CARD NO.	FUNCTION
RPF303	ON/OFF-35 ft. Retro Control	T360	Single Timer (OFF Delay)
RXPF303	ON/OFF-6 ft. Prox Control	T310	Single Timer (ON Delay)
RYPF303	ON/OFF-14 in. Prox Control	T330	Dual Timer (OFF Delay and ON Delay)
RCPF303	ON/OFF-300 ft. Control	T320	One-Shot Timer (OFF Delay)
LRML	300 ft. Light Source	T300	Five-Function Timer
P380	Retro-reflector 3" diameter	T342	Batch Counter
P875	Swivel Bracket	T370	Delayed One-Shot Timer
P1193	Weather Shield	T380	Shift Register (Delay Line)
		T390	Over or Under Speed Detector
		T399	Output Latch
		T1330	Repeat Cycle Timer
		T349	Single-Digit Toggle Batch Counter
		T3200	Long Delay* One-Shot Timer (OFF Delay)
		T3600	Long Delay* Single Timer (OFF Delay)

\*To 40 hours

For more detailed information on cards,  
see Bulletin 979



# Specifications

**LIGHT BEAM DISTANCE:†**

- RPF303 0 - 35 feet off 3" diameter reflector
- RXPF303 0 - 6 feet off 90% diffuse white surface
- RYPF303 0 - 14 inches off 90% diffuse white surface
- RCPF303/LRML 0 - 300 feet

†Maximum ranges apply for clean indoor conditions only. Contact the factory for dirty or outdoor applications.

**INPUT:**

- Standard — 120V ± 10% 60 Hz.
- Optional — 120V ± 10% 50-60 Hz.
- Optional — 230V ± 10% 50-60 Hz.
- Optional — 12 VDC; -1V, +4V at .15 amps DC Max.
- Optional — 12VAC; -3V, +1V at .18 amps AC Max.; 50-60 Hz.
- Optional — 24 VDC; -4V, +6V at .18 amps DC Max.
- Optional — 24 VAC; -4V, +6V at .22 amps AC Max.; 50-60 Hz.

**POWER CONSUMPTION:** 5VA Max.

**RESPONSE TIME:** .01 sec. for circuit, .03 including relay

**OUTPUT:** Standard-Relay: DPDT contacts rated for 100,000 cycles at 120VAC or 28VDC, 10A resistive; 10,000,000 mechanical. See Fig. A.

- Optional - Solid State AC Switch: SPNO contacts rated at 2.0 amps Max., .1 amps Min. See Fig. B.
- Optional - 'G' Logic output: SPNO NPN transistor  $V_{ce(sat)} = .5V$  Max. @ 10 ma. 1.5V Max. @ 100 ma.  $V_{ceo} = 30$  VDC Max.,  $I_c = 100$  ma Max. See Fig. C1.
- Optional - 'GA' Logic output: Dual transistor output containing one NPN with same characteristics as 'G' output and one opto-isolated transistor  $V_{ce(sat)} = 1.0V$  Max. @ 4ma.  $V_{ceo} = 30$  VDC Max,  $I_c = 4$  ma Max. See Fig. C2.

**AMBIENT LIGHT TOLERANCE:** 10,000 foot-candles of sunlight

**TIMING ACCURACY:** Repeat Accuracy ± 1%. Accuracy over extremes of temperature and line voltage -20% + 10% (typical).

**SOURCE:** GaAs infrared LED. Life-indefinitely long.      **SENSOR:** Silicon phototransistor

**AMBIENT OPERATING TEMPERATURE:** -40°C to +55°C (-40°F to +131°F)

**ENCLOSURE:** Die Cast Aluminum, epoxy gray painted, gasket sealed, NEMA 1, 3, 4, 5, 12, 13 tapped in bottom for 3/8" conduit.

**SHIPPING WEIGHT:** Three pounds.

## Options

**SOLID STATE AC SWITCH OUTPUT**

Opto-isolated triac features zero-crossing and built-in snubber. See Fig. B. Triac functions as a SPNO switch or a SPNC switch, depending on phase connection. This output is used to handle loads with a high repetition rate or when very long contact life is needed. For 120VAC only. Not UL Listed. Add "K" to end of model number. Example: RPF303K

**LOGIC OUTPUT**

An open-collector NPN transistor or an opto-isolated NPN transistor. See Fig. C1 or C2. This output is used primarily to interface the output of the control to logic devices such as programmable controllers, computers and electronic counters. Not UL Listed. Add "G" or "GA" to end of model number. Example: RPF303G

**ANTI-FOG LENS HEATER**

This option consists of a heater located behind the lens which warms the lens to prevent moisture condensation. The heater dissipates five (5) watts of heat at 120VAC. This option is recommended for outdoor and severe environments. Not UL Listed. Add an "H" behind the R in the model number. Example: RHPPF303

**120VAC and 230VAC, 50-60 Hz. INPUT**

This option allows the unit to operate on a 120V or 230V single phase supply at 50 or 60 Hz. See Fig. D. It should be noted that maximum relay contact current should be halved for operation at 230VAC. Not UL Listed. Add a "T" behind the R in the model number for 120V and add an "E" behind the R in the model number for 230V. Example: REPF303.

**12VAC 50-60 Hz., 12VDC, 24VAC 50-60 Hz. and 24VDC INPUT**

These options allow the units to be operated from 12V or 24V. This is often desirable depending on the available system power supply, or applicable safety standards. See Figs. D, E, F and G for input information. Circuit common is connected to the case. UL Listing not applicable. The input code is specified by a letter following the R in the model number. Examples: RAPPF303, (12VAC); RDPF303, (12VDC); RBPF303, (24VAC); RWPF303, (24VDC).

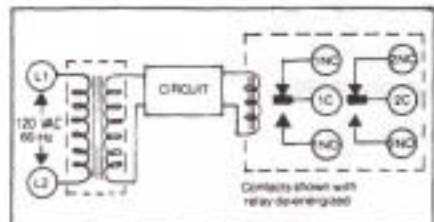

Fig. A: Standard Input/Output

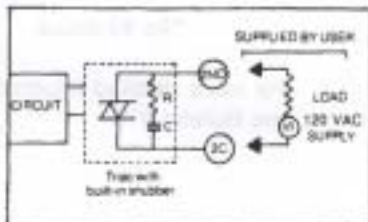

Fig. B: Solid State AC Switch Output (K)

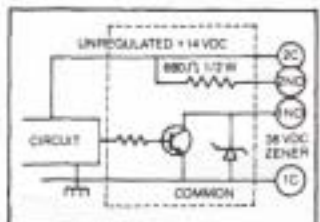

Fig. C1: Logic Output (G)

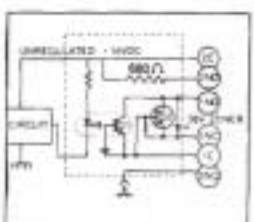

Fig. C2: Logic Output (GA)



## Operation

**THE R SERIES FUNCTIONS AS AN ON/OFF CONTROL WITH NO TIMING BOARD INSERTED.** The phase switch allows the output to be energized with the light beam unbroken or broken. For LIGHT energized operation, set the phase switch in the position labeled "LIGHT." For DARK energized operation, set the phase switch in the position labeled "DARK."

A sensitivity adjustment is available to reduce control sensitivity. Turn pot counter-clockwise to decrease sensitivity.

A unique proportional red LED alignment indicator is provided. The more light "seen" by the sensing circuit, the brighter it glows. Reducing the sensitivity pot will reduce indicator intensity.

The phase switch also determines whether the timer times out light or times out dark. The last digit of the plug-in timer number denotes the adjustable time range on timing controls. Available timing ranges are shown below. Turn timing pot clockwise to increase delay.

Range No. 0 — .1 - 10 sec. (standard)	Range No. 6 — .04-5 sec.
Range No. 2 — .005-.5 sec.	Range No. 7 — .2-23 sec.
Range No. 3 — .01-1 sec.	Range No. 8 — .9-90 sec. (add'l chg.)
Range No. 5 — .02-2.5 sec.	

Example: RPT363 uses the T363 timing board with the No. 3 (.01-1 sec) time delay.  
Note: These ranges do not apply to the T3200 or T3600 cards.

In discussing timing functions, the following phrases will appear:

**Light Energized** - means the output energizes when the sensor "sees" light.

**Dark Energized** - means the output energizes when the sensor "sees" dark.

**Time out Light** - refers to timing controls whose time delay begins when the sensor "sees" light. Relay reversal occurs at end of delay. Light beam interruption resets time delay.

**Time out Dark** - refers to timing controls whose time delay begins when the sensor "sees" dark. Relay reversal occurs at end of delay. Light beam restoration resets time delay.

The timing functions use an RC (resistor-capacitor) network to determine the time delay. It should also be noted that when using the relay, DPDT contacts are provided. Therefore, any relay action gives two sets of contacts closing and opening.

### OUTPUT SEQUENCE DESCRIPTIONS:

**On/Off:** Output responds immediately. Output may be DARK energized or LIGHT energized, as selected by the phase switch position.

**Single Timer-OFF Delay:** Output is LIGHT-energized, time out dark or DARK energized, time out light as selected by the phase switch position. Built-in inhibit circuit prevents false trip when power is turned on.

**Single Timer-ON Delay:** Same as above except output is LIGHT-energized, time out LIGHT or DARK-energized, time out DARK.

**One-Shot:** Timing is fired by a light-to-DARK or dark-to-LIGHT change, as selected by the phase switch position. Output delays de-energization (dropout).

**Delayed One-Shot:** Output energizes for an adjustable (T1) beginning an adjustable time (T2) after the completion of either a LIGHT or DARK signal. Trigger on either LIGHT or DARK signal selected by the phase switch position. Built-in inhibit circuit prevents false trip when power is turned on. Output pulse duration (T1) is adjustable from .02 to 2.5 seconds. Delay (T2) until pulse follows normal available time delay ranges.

**Dual Timer:** Output times out light **and** times out dark. Output may be LIGHT or DARK energized, as selected by the phase switch position.

**Batch Counter:** Set count between 1 and 99 on two decade switches. When the set count is reached, output energizes for approximately 0.1 second while count automatically resets for next batch.

**Latch:** Output latches ON at the instant the light beam is either blocked or restored as determined by the phase switch position. Latch is released by momentarily interrupting input power to the control.

**Delay Line (128-bit shift register):** Output responds in the same pattern as the signal occurred at the input, only delayed by the amount of time delay setting.

**Five Function Timer:** Can select any one of five most commonly used functions by means of a 4-position DIP switch: (1) Single timer - OFF delay (2) single timer - ON delay (3) dual timer (4) one shot - OFF delay (5) one shot - ON delay

**Over or Under Speed Detector:** Output energizes in the overspeed condition and de-energizes in the under speed condition.

**Repeat Cycle Timer:** Output cycles on and off as long as an input is present.

**Toggle Batch Counter:** Counts input pulses and switches the output when the predetermined number (1 to 9) of counts is reached.

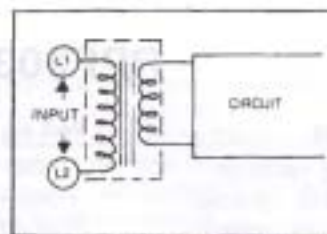

Fig. D: 120 VAC 50-60 Hz input (T)  
230 VAC 50-60 Hz input (E)  
24 VAC 50-60 Hz input (B)

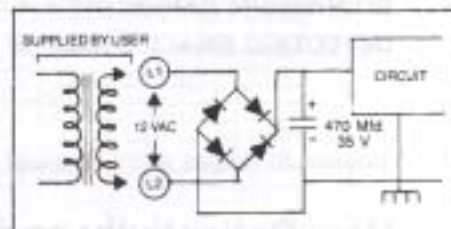

Fig. E: 12 VAC 50-60 Hz Input (A)

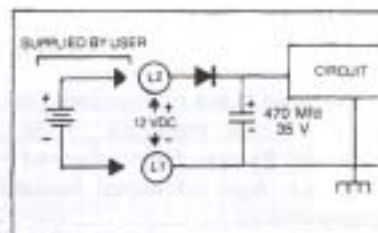

Fig. F: 12 VDC Input (D)

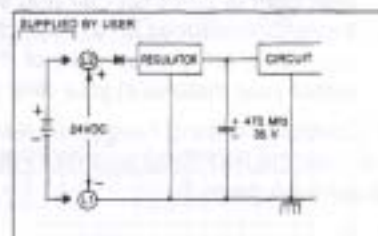

Fig. G: 24 VDC input (W)

## RPF303 Range Off Retro Surfaces

Surface	Part No.	Max. Range†	Surface	Part No.	Max. Range†
3" dia. reflector	P380	35 feet	1 1/4" x 3" reflector	P380E	20 feet
1 3/4" dia. reflector	P380A	16 feet	1" x 1" retro tape	7610	4 feet
1 1/4" dia. reflector	P380AB	14 feet	1" x 1" retro tape	3870	3 feet
3/4" dia. reflector	P380B	12 feet	1" x 1" retro tape	7800	2 feet
1/2" dia. reflector	P380C	10 feet			

**NO MINIMUM RANGE:** There is no minimum range with the above retro-reflective materials.

**DETECTING SMALL OBJECTS:** If objects significantly smaller than the lens must be detected, use a small retro-reflector or mask down a larger one. The maximum light beam distance must be reduced as shown above.

†Maximum ranges apply for clean indoor conditions only. Contact the factory for dirty or outdoor applications.

## How Reflectivity and Dirt Affect Range of RXPF303 and RYPF303

The table to the right shows the typical reflectivity of various materials. This determines the minimum Excess Gain required for operation in clean air. Add additional Excess Gain for dirty environments.

Example: If material reflectivity requires an excess gain of 2 in clean air and your dirty environment requires an excess gain of 5, then you need an excess gain of 10 (2 x 5) to detect your material in your dirty environment.

Control operating range can then be determined from the RXPF303 and RYPF303 Excess Gain graphs on page 5.

Material	Typical Reflectivity	Required Excess Gain For Clean Air
Kodak White Test Card	90%	1.0
White Bond Paper	82%	1.1
Kraft Paper	80%	1.1
Clear White Pine Wood	75%	1.2
Black Polyester Cloth	25%	3.6
Old Black Conveyor Belting	16%	5.6
New Black Conveyor Belting	9%	10.0
3M Nextel Flatblack Paint	4%	22.5

**RULE OF THUMB:** When distinguishing one material from another, the ratio of one reflectivity to another should be 2:1 minimum.

## Dimensional Drawings

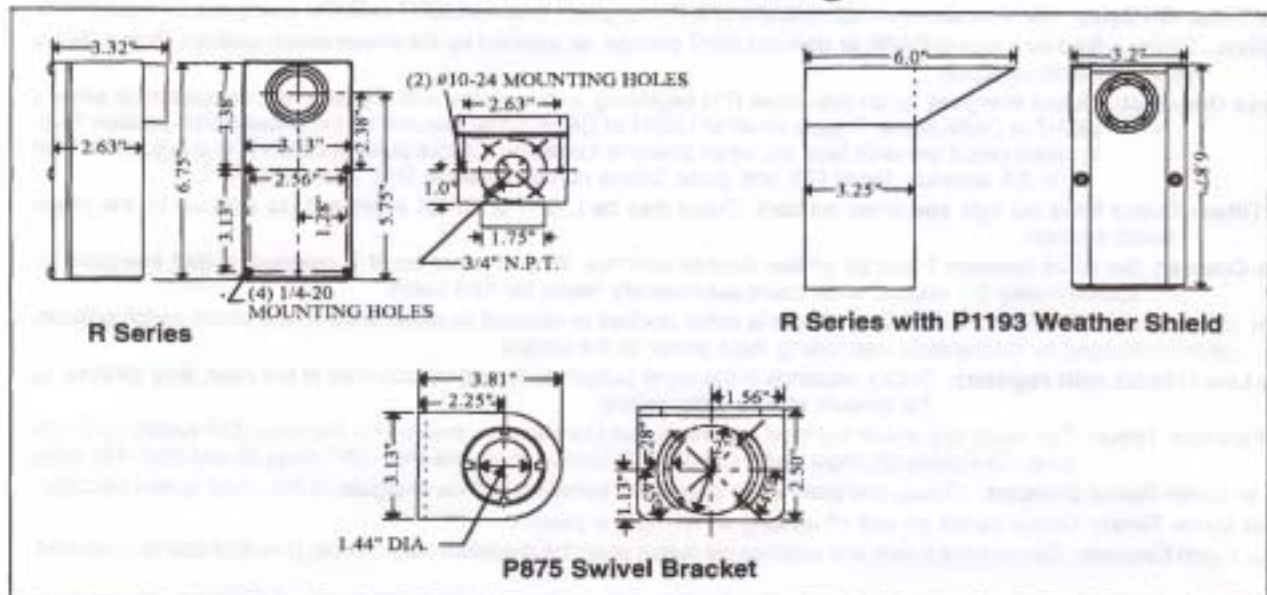

ELWOOD CORPORATION, 195 West Ryan Road, Oak Creek, WI 53154-4401 U.S.A.

Telephone: 414-764-7500

www.elwood.com

Fax: 414-764-4298



## EXCESS GAIN

How well a photoelectric control can perform under less-than-ideal conditions is measured in terms of Excess Gain. Excess Gain is the ratio of the light signal available to the light signal necessary for the control to barely work. The graphs below plot this factor versus range from specific targets. If degrading factors such as dirt, a poorly reflective surface, or misalignment exist, an Excess Gain greater than one (1) is required. How much Excess Gain is required for the application is determined by the customer. An Excess Gain of 3-5 should be allowed for light industrial environments, and 5-8 for moderately dirty environments.

### TYPICAL EXCESS GAIN vs. RANGE

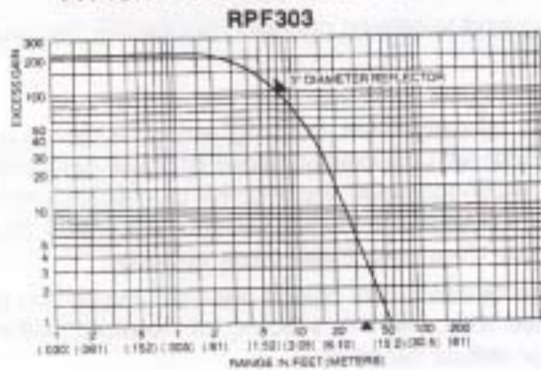

### RXPF303

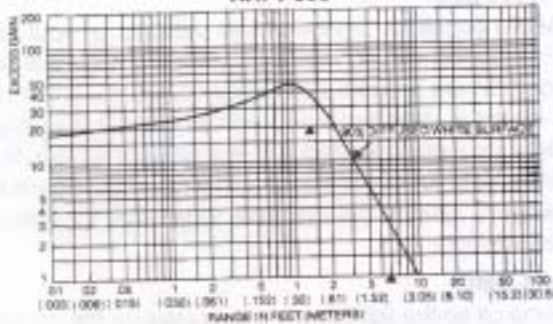

### RYPF303

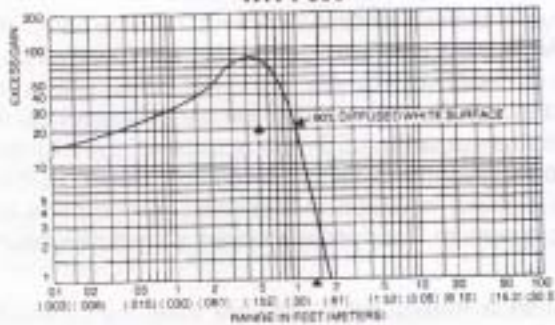

### RCPF303 / LRML

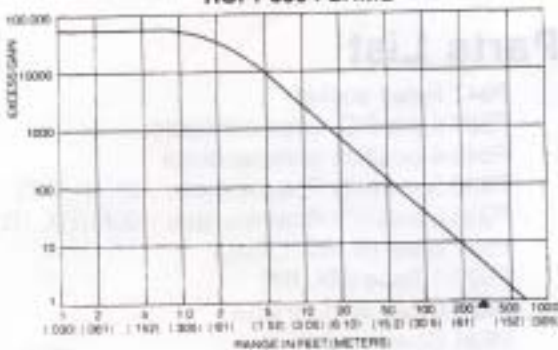

### EFFECTIVE BEAM DIAMETER\* vs. RANGE

#### RPF303

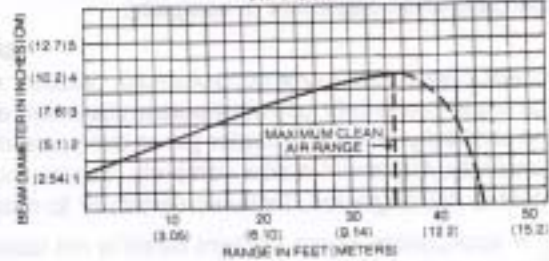

#### RXPF303

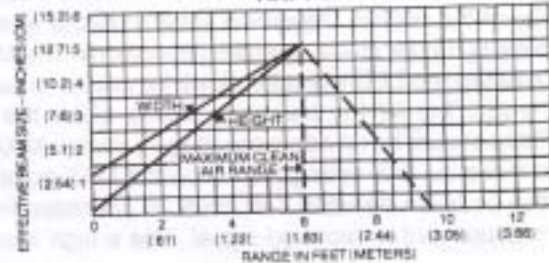

#### RYPF303

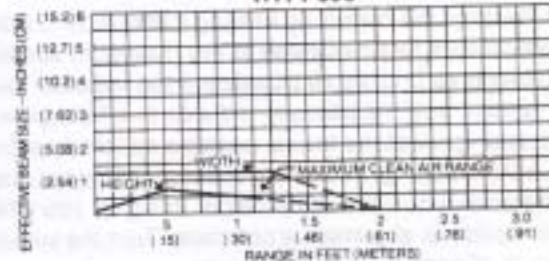

#### RCPF303 / LRML

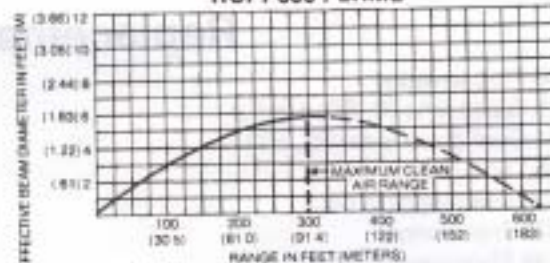

\* EFFECTIVE BEAM DIAMETER is defined as that portion of the radiation pattern that is sufficiently intense for detection.

ELWOOD CORPORATION, 195 West Ryan Road, Oak Creek, WI 53154-4401 U.S.A.

Telephone: 414-764-7500

www.elwood.com

Fax: 414-764-4298



## Installation

WAD 021003

The R Series is easy to set up and install. The P875 Swivel Bracket is available as an option to provide easy installation and alignment. Here is a brief guide:

1. Mount the control to a solid foundation to avoid a shift with time causing misalignment and erratic operation.
2. Connect LINE and LOAD wiring. The relay contacts are dry switches and do not supply voltage of themselves. Voltage must be applied from an external source. Plug-in relay may be removed for easier wiring.
3. To make the alignment process easier, remove any timing card to convert operation to ON/OFF. Replace the card when alignment is complete.

### RPF303

4. Power control and move control and/or reflector to achieve best alignment. Best alignment is achieved by turning the sensitivity fully clockwise to maximum and align until red LED indicator glows brightest. Decrease the sensitivity until the indicator glows dimly and continue aligning to obtain the brightest glow at the lowest sensitivity. Alignment is now complete. Secure mounting of the control to the foundation, making sure alignment is not degraded. Increase sensitivity to maximum (fully clockwise). Install cover securely.

(For applications where the light beam is not totally blocked or translucent objects are used, the sensitivity may have to be reduced for best performance. If unwanted source light is reflecting off the object, either angle beam off of perpendicular to the object's surface or reduce sensitivity.)

### RXPF303 and RYPF303

Power the control. Determine the MAXIMUM and MINIMUM sensitivity potentiometer settings for your application under actual operating conditions. The MAX is the highest setting where undesired objects are not detected (no LED indicator glow). Where no undesired objects are present this will be at **full** maximum on the pot. The MIN is the lowest setting where the target object is detected (LED indicator at full intensity). There should be an adequate range between MAX and MIN for a good application. It is often good practice to make the final setting just below the MAX point to compensate for dirt build-up with time. Readings may also be taken between Test Point #5 (identified in copper) and ground (DC voltage) to provide an analog measurement of received signal. Use a high impedance voltmeter.

### RCPF303 and LRML

Power both the light source and control. "Aim" the light source so the light beam is centered on the control lens. The beam diameter at 100' is about three (3) feet and at 50' is about two (2) feet.

Now align the control by rotating it from side to side and up and down for best alignment. Turn the sensitivity adjustment fully clockwise to the maximum sensitivity. Align the control until the red alignment indicator is glowing as brightly as possible. If the indicator glows to its maximum intensity, decrease the sensitivity adjustment until the intensity reduces to a faint glow and continue alignment to achieve the brightest LED indicator glow at the lowest possible sensitivity setting. Now re-adjust the LED Light source for the brightest LED indicator glow on the control at the lowest possible control sensitivity setting. If you are spanning a long distance, you will need a helper to signal you when the indicator increases in brightness. When this is accomplished, alignment is complete. Turn the sensitivity to maximum. Then replace covers and secure mountings of control and light source.

(For applications where the light beam is not totally blocked or translucent objects are used, the sensitivity may have to be reduced for best performance.)

## Replacement Parts List

P846 Plug-in relay  
P829 Glass lens (R, RC, LRML)  
P891 Dual glass lens (RX, RY)  
P835 Lens gasket  
P863 Lens retaining ring  
P1021 Transformer  
P1188 Phototransistor (R)  
P1186 Phototransistor (RX, RY, RC)  
P1189 LED (R)  
P1187 LED (RX, RY, LRML)

P847 Relay socket  
P867 6-pin P.C. edge connector  
P848 4-position terminal block  
P880 Sensitivity Potentiometer - 2K (R, RC)  
P936 Sensitivity Potentiometer - 50K (RX, RY)  
P827 Base (R, RC, LRML)  
P827-1 Base (RX, RY)  
P828 Cover with window  
P834 Cover gasket

**ELWOOD CORPORATION, 195 West Ryan Road, Oak Creek, WI 53154-4401 U.S.A.**

Telephone: 414-764-7500

www.elwood.com

Fax: 414-764-4298

## Servicing

**CLEANING: Lens:** always keep the lens clean for best performance. The lens is glass, so no special care need be taken when cleaning.

**Plug-In Function Board & Connector:** clean gold-plated contacts with alcohol and a soft cotton cloth as needed.

**Control:** the cover and gasket must be in place at all times during operation to prevent entry of foreign material that can cause malfunction.

**LENS REMOVAL:** Hook the lens retaining ring and pull it out. The lens should then come out. When replacing the lens, make sure the lens gasket is in place and push the retaining ring in evenly and firmly. Note that the RX/RV lens is notched for proper orientation.

**RELAY REMOVAL:** The entire relay merely unplugs for easy changing.

**TROUBLESHOOTING:** With the exception of the plug-in relay, all components are solid state with indefinite life. If trouble occurs, the following suggestions should uncover the problem. Begin by removing any timing card to convert operation to ON/OFF. If control begins functioning properly as ON/OFF, check timing card. Do not loosen the two pre-adjusted sealed screws holding the optical housing on the RPF303.

### TROUBLE

A. Relay (output) does not energize

### LIGHT PHASE

1. Light beam mis-aligned.
2. Operating range too long for conditions.
3. Sensitivity set too low.
4. Lens or reflector dirty or broken.
5. Input voltage out of allowable tolerances.
6. LED or phototransistor malfunction.

### DARK PHASE

1. Incomplete light beam blockage. See Installation Step 3 on page 6.
2. Sensitivity set too high for conditions.
3. Input voltage out of allowable tolerances.

B. Relay (output) does not de-energize

1. Incomplete light beam blockage. See Installation Step 3 on page 6.
2. Sensitivity set too high for conditions.
3. Input voltage out of allowable tolerances.

1. Light beam mis-aligned.
2. Operating range too long for conditions.
3. Sensitivity set too low.
4. Lens or reflector dirty or broken.
5. Input voltage out of allowable tolerances.
6. LED or phototransistor malfunction.

C. Timing below minimum or erratic.

Insufficient LIGHT time.

Insufficient DARK time.

D. Relay (output) actuates but LOAD circuit does not respond.

Copper printed wiring under relay socket blown open due to overload or short in LOAD circuit. Relay contacts burned out.

**FACTORY SERVICE:** For direct factory service, send unit with a purchase order to cover repair charges along with a description of the problem to AUTOTRON, INC. at the address on the front cover.