

**No. 553-500 ELWOOD WYCO "QUICK-CHANGE" HANDPIECE**  
Standard Equipment with 1/3 and 1/2 H.P. Machines

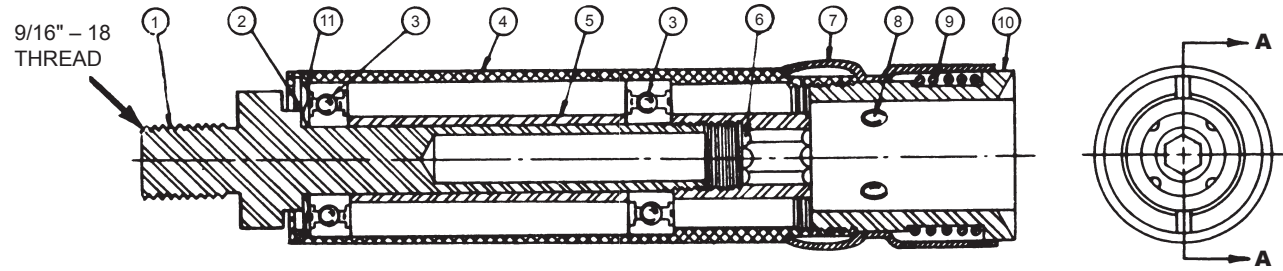

No.	Part No.	Req.	Part Name
1	793-503	1	Spindle
2	705-513	1	Retaining Ring
3	095-514	2	Ball Bearings
4	763-549	1	Handpiece Shell
5	783-528	1	Spacer
6	383-544	1	Hex Driver
7	764-322	1	Quick Change Sleeve
8	093-336	4	3/16" Steel Balls
9	804-320	1	Q.C. Spring
10	773-102	1	A.C. Socket
11	802-202	1	Wave Washer

**WHEEL ARBORS:**

Hole Size	Wheel Width	Part No.
3/8"	up to 1/2"	023-050
1/2"	up to 1"	024-050
1/2"	1 - 1 1/2"	025-050
5/8"	1 - 1 1/2"	026-050

ARBOR ADAPTERS		
3/8" - 16	-	023-051
1/2" - 13	-	025-054
3/8" - 24	-	023-056

See table on previous page

**No. 555-510 ELWOOD WYCO "QUICK-CHANGE" HANDPIECE**  
Standard Equipment with 3/4 and 1 H.P. Machines

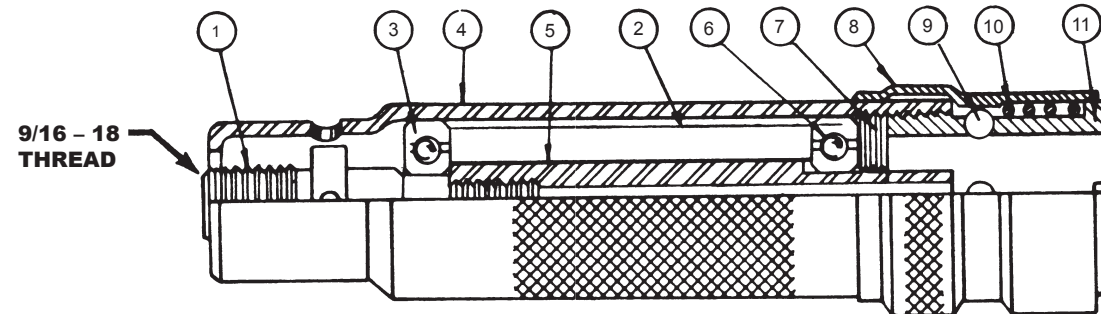

No.	Part No.	Req.	Part Name
1	795-072	1	Spindle
2	785-280	1	Spacer
3	098-334	1	Bearing
4	765-501	1	Handpiece Shell
5	385-442	1	Hex Sleeve
6	098-332	1	Bearing
7	708-380	1	Lock Ring
8	765-322	1	Sleeve
9	091-400	4	1/4" Steel Ball
10	805-320	1	Spring
11	778-380	1	Socket

**HANDPIECE MAINTENANCE AND LUBRICATION:**

No.s 553-500 and 555-510 Handpieces: Both have shielded and sealed precision ball bearings – and are lifetime lubricated. To remove bearings in No. 553-500 Handpiece, remove Retaining Ring (No. 2, above). The spindle and ball bearing assembly will come out freely. To remove bearings in No. 555-510 Handpiece, remove Quick-Change coupling assembly – using edge side of wrench. Spindle and Ball Bearing assembly removes freely.

*Do not dip ball bearings in solvent to clean – Wipe with clean rag for inspection.*

**QUICK-CHANGE COUPLINGS:** These should be cleaned daily with an air hose to blow out all dust. A few drops of oil into the ball sockets at each cleaning will assure free operation.

# SERVICE MANUAL

## INDUSTRIAL FLEXIBLE SHAFT MACHINE



Elwood Wyco Direct Drive Machines are available in 1/3, 1/2, 3/4, and 1 Horse Power models. Standard Equipment furnished with above machine includes: 1 Flexible Shaft, 1 Handpiece, 1 set of Wheel Arbors and 1 set of Wrenches.

Catalog No.	H.P.	Speed R.P.M.	Part Number
49-2	1/3	1725	490-202
49-3	1/2	3450	490-203
49-4	1/2	1725	490-204
49-5	3/4	3450	490-205
49-6	3/4	1725	490-206
49-14	1	3450	490-214

The Elwood Wyco Industrial Grinders described in this manual are single speed, 115/230 volt, 1 phase, 60 cycle motors. The Flexible Shafts are neoprene covered casings with cores of high-carbon steel wire. The Handpieces are equipped with exclusive Elwood Wyco "Quick Change" couplings. Arbors and Adapters are furnished with each machine for attaching accessories.



195 West Ryan Road • Oak Creek, Wisconsin 53154  
1-800-527-7500 or 414-764-7500 • Fax: 414-764-4298

## Exploded View Of ELWOOD WYCO INDUSTRIAL FLEXIBLE SHAFT MACHINE

(SEE INDEXED PARTS LIST ON FOLLOWING PAGE)

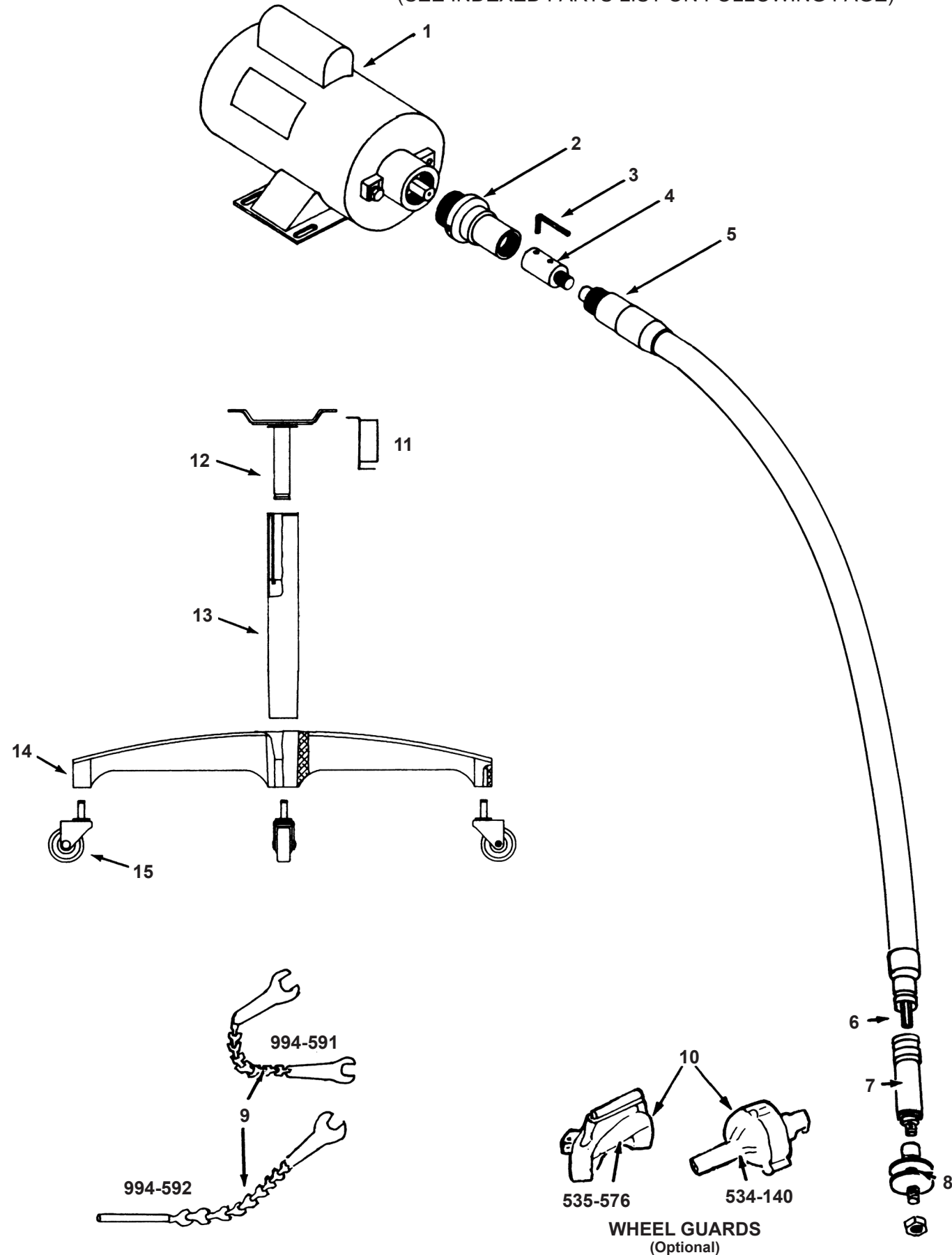

## ELWOOD WYCO DIRECT DRIVE MACHINE

# PARTS LIST

(FOR ITEMS IN ASSEMBLY ON PREVIOUS PAGE)

ELWOOD WYCO CATALOG NUMBER			49-2	49-3	49-4	49-5	49-6	49-14
REF.	NAME OF PART	REQ'D	Horse Power - Speed R.P.M.					
			1/3 - 1725	1/2 - 3450	1/2 - 1725	3/4 - 3450	3/4 - 1725	1 - 3450
1	Motor Assembly	1	420-202	420-203	420-204	420-205	420-206	420-214
2	Shaft Support	1	344-100					
3	5/32" Hex Key	1	414-037					
4	Motor Coupling	1	342-024	342-003	342-024	342-056		342-014
5	Casing Assembly	1	211-015	211-206		211-217		211-507
6	Core Assembly	1	321-015	321-206		321-307		321-507
7	Handpiece	1	553-500			555-510		
8	Wheel Arbors	1 Set	023-050, 024-050, 023-057 023-056 and 025-054			025-050, 026-050, 023-051 023-056 and 025-054		
9	Wrench Set	1	994-591			994-592		
10	Wheel Guard (optional)	1	534-140			535-576		

### COMPONENT PARTS FOR QUADPOD ASSEMBLY (NO. 084-074)

REF.	NAME OF PART	NO. REQUIRED	PART NO.
11	Handy Hanger	1	573-852
12	Base Plate Assembly	1	083-094
13	Post with Bushing	1	853-314
14	4 Leg Base	1	644-074
15	Caster Wheel	4	894-722

### NUTS, BOLTS AND LUBRICANT

TYPE OF HARDWARE	PART NO.	NO. REQUIRED
5/16" - 18 x 1" long carriage bolts and nuts - motor to base	431-453	4
5/16" flat washer - motor to base	883-125	4
5/16" lock washer - motor to base	883-126	4
5/16" - 18 x 1/4" long socket head set screw - motor coupling	434-030	2
5/16" - 18 x 5/8" long hex screw - shaft hook to motor	402-108	1
5/16" lock washer - shaft hook to motor	883-126	1
Flexible Shaft Lubricant (14 oz. tube)	555-143	-

### LUBRICATION INSTRUCTIONS

**FLEXIBLE SHAFT:** The Casing (No. 5, previous page) should be unscrewed from the shaft support (No. 2, previous page) and moved down along the core about 18 inches. Apply Elwood Wyco Flexible Shaft Lubricant (No. 555-143) to all sides of the core and re-install casing. (The lubricant will travel the full length of the shaft during operation.) Do not over-lubricate, as this may force grease into the handpiece which may cause over-heating of the handpiece.

**MOTOR:** This motor is supplied with prelubricated ball bearings and requires no further lubrication.

**ORDER PARTS FROM YOUR NEAREST ELWOOD WYCO DISTRIBUTOR**

Specifications subject to change without prior notice.