

No. 10 - Industrial Flex Shaft

For Use With a 1/4 or 1/3 hp Power Unit

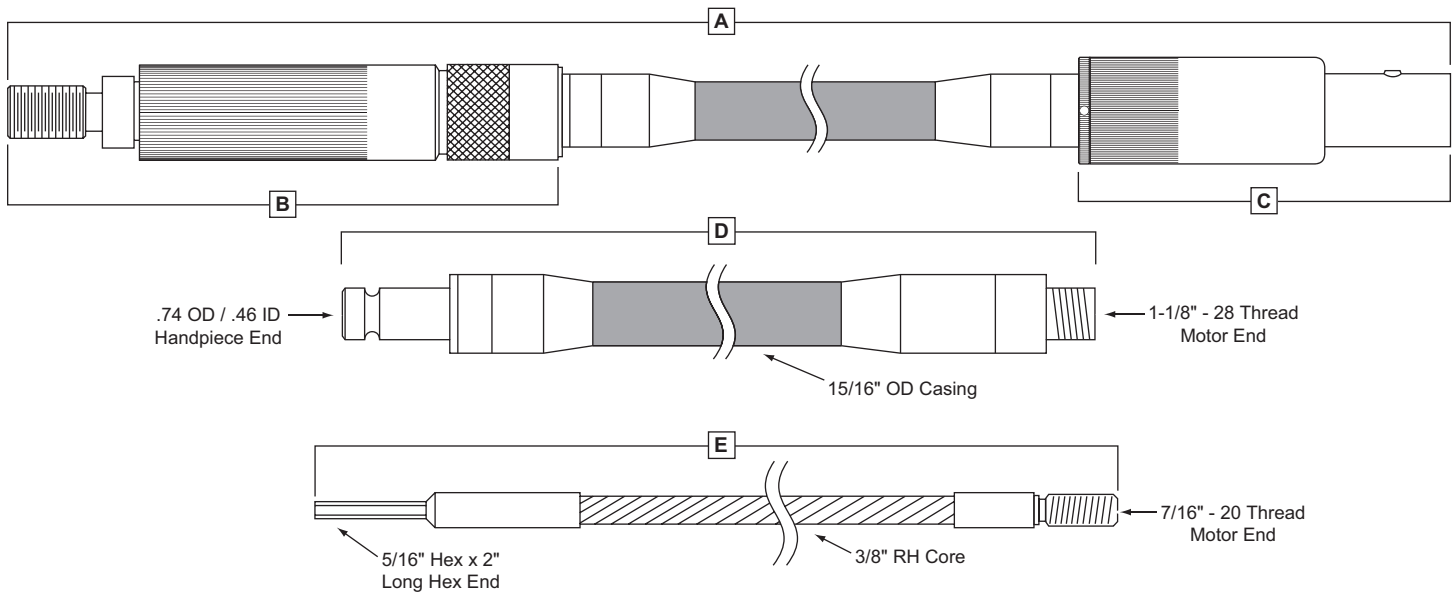

Item "A" #481-014 — Assembly, #10 Industrial Flex Shaft; 1/2" Diameter (5 ft. long)

Item	EPN	Description
B	553-500	Assembly, Handpiece, 3500 (Spindle is 9/16" - 18" Thread)
C	343-400	Assembly, 3400 Coupling; 1/2" I.D. Size
D	211-015	Assembly, Casing, K-10 (Overall Length is 55")
E	321-015	Assembly, Core, C-10 (Overall Length 57-1/4")

Item "A" #481-015 — Assembly, #10 Industrial Flex Shaft; 5/8" Diameter (5 ft. long)

Item	EPN	Description
B	553-500	Assembly, Handpiece, 3500 (Spindle is 9/16" - 18" Thread)
C	343-401	Assembly, 3400 Coupling; 5/8" I.D. Size
D	211-015	Assembly, Casing, K-10 (Overall Length is 55")
E	321-015	Assembly, Core, C-10 (Overall Length 57-1/4")

For a detail drawing of item "B" and "C", see other side of page.

General Instructions

The #10 Flex Shaft is 5 ft. long and is available with 1/2" or 5/8" bore motor drives. Elwood-Wyco Wheel Arbors for grinding wheels, wire brushes, etc. with 3/8", 1/2" or 5/8" arbor holes are available. Also available are Rasp Adapters for using Rasps with internal threads of 3/8" - 16 and 1/2" - 13.

No. 10 - Industrial Flex Shaft

For Use With a 1/4 or 1/3 hp Power Unit

No. 3500 "Quick Change" HANDPIECE

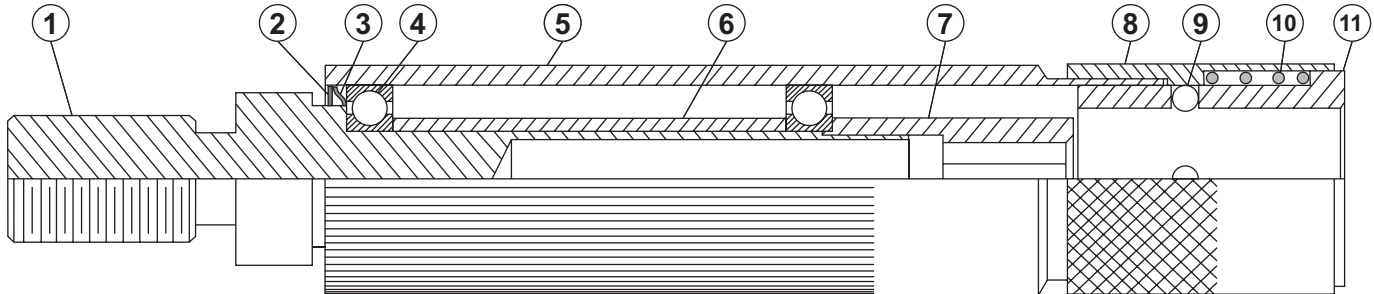

PARTS LIST

Item	EPN	Qty.	Description
1	793-503	1	Spindle
2	705-513	1	Ring, Retaining
3	802-202	1	Washer, Wave
4	095-514	2	Bearing, Ball
5	763-549	1	Handpiece, Shell
6	783-528	1	Spacer

Item	EPN	Qty.	Description
7	383-544	1	Driver, Hex
8	764-322	1	Sleeve, Quick-Change
9	092-202	4	Ball, Steel
10	804-320	1	Spring, Quick-Change
11	773-102	1	Socket, Handpiece

Disassembly Instructions: (a) Remove retaining ring (2) and pull entire bearing and spindle assembly (1, 4, 6, 7 & 8) from housing. (b) Remove hex driver (7) from spindle (1) to remove bearings (4 & 7) for cleaning and inspection. The bearings are lifetime lubricated and need no further lubrication. **DO NOT** dip bearings in solvent. Wipe with clean cloth.

No. 3400 Ball Bearing Coupling

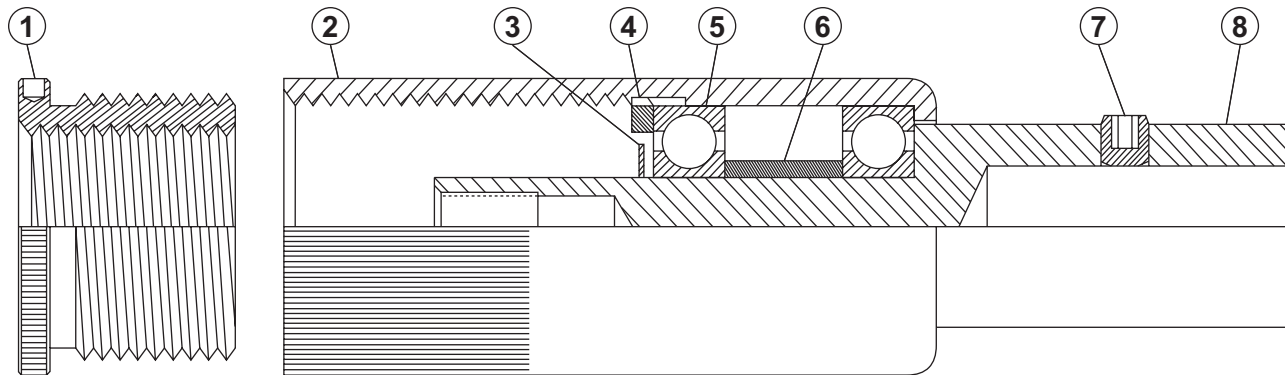

PARTS LIST

Item	EPN	Qty.	Description
1	175-360	1	Bushing, Reducing
2	765-502	1	Shell, Coupling; Plated
3	703-405	1	Ring, Retaining
4	708-380	1	Ring, Lock
5	098-334	2	Bearing, Ball

Item	EPN	Qty.	Description
6	785-282	1	Spacer, Motor Coupling
7	434-030	1	Screw, Soc Set; 5/16" - 18"
8	343-402	1	Coupling, Motor; 1/2"
8	343-403	1	Coupling, Motor; 5/8"

Disassembly Instructions: (a) Remove Bushing (1), Lock Ring (4) and Retaining Ring (3). (b) Pull Bearing assembly from Coupling end. The bearings are lifetime lubricated and need no further lubrication. **DO NOT** dip bearings in solvent.

Lubrications Instructions: Lubricate core after every 50 hours of operation using Elwood-Wyco lubricant. Loosen the casing to expose about 18" of core and apply a liberal amount of lubricant to the exposed section of core and re-install the casing. The lubricant will travel the full length of the shaft when in use.