

Heavy Duty Electric Fish Scaler

• Saves Time and Hard Work

Anyone can do fish scaling—fast—with the Elwood-Wyco Electric Fish Scaler. It will not harm the skin. Handles small or large scales. Safety cutter guard protect the operator.

SPECIFICATIONS

Motor: 1/4 hp, 115-volt, AC, 1-phase, 60 cycle, 1725 rpm motor is mounted on a combination bench and suspension base. Motor pull switch is connected to the shaft hook—shuts off automatically when shaft is placed on the hook. Constant speed motor with 8 foot, 3-wire cord and safety plug.

Flexible Shaft: Power from the motor is transmitted to the handpiece through the flexible shaft. The flexible shaft is insulated from the motor and safe from electrical shock.

Core and Casing: Length 5 ft., Core No. C-10 (321-015), Casing No. K-01 (211-025).

Handpiece: Catalog No. 250-FSC is rust-proof plated and stainless steel, Quick Change, and furnished with eight easily replaceable stainless steel cutter wheels and safety guard.

Support hook is detachable for bench operation.

Pull-Switch with insulated cord for added safety.

Hang it anywhere. FS-01 weighs 25 lbs. (Less handpiece).

Heavy Duty Fish Scaler Complete

Catalog No. FS-01: Elwood-Wyco Fish Scaler (pictured above); complete with flexible shaft, core and casing, 5 ft. No. 250-FSC "Quick Change" Handpiece (pictured right).

Catalog No. 250-FH: Elwood-Wyco "Quick Change" handpiece.

Catalog No. 314-G: Elwood-Wyco safety guard for Scaler cutter.

Catalog No. 314-FS: Elwood-Wyco Fish Scaler cutter.



Prices and specifications subject to change without prior notice.

Maintenance Instructions

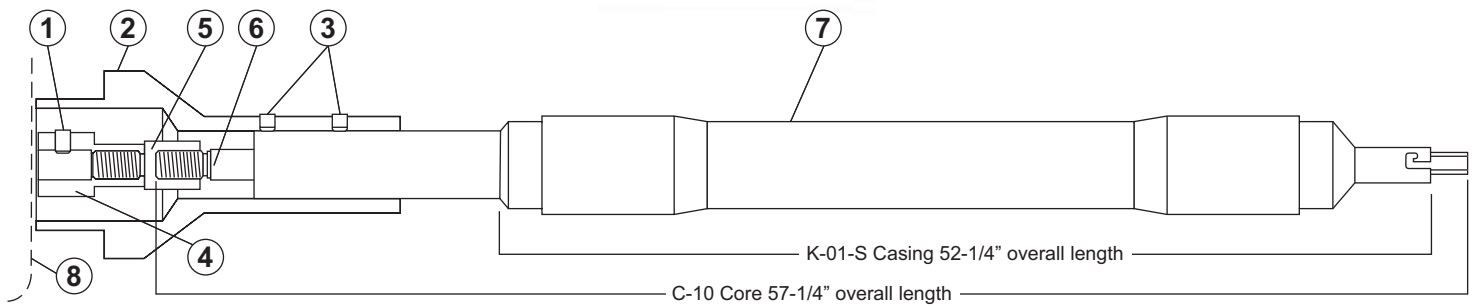

Item No.	Part No.	Qty.	Part Name
1	434-030	1	5/16" x 18 thread x 1/4" set screw
2	344-150	1	Shaft Support
3	434-013	2	1/4" x 28 thread x 1/4" set screw
4	342-050	1	Motor Coupling

Item No.	Part No.	Qty.	Part Name
5	022-240	1	Insulating Coupling
6	321-015	1	Core-Flexible Shaft (3/8" diameter)
7	211-025	1	Casing-Flexible Shaft
8	410-101	1	Motor (not shown)

Maintenance and Lubrication

Flexible Shaft: Lubricate flexible shaft about once a month.

To lubricate - (A) Loosen 2 socket set screws (Ref. No. 3)

(B) Pull shaft off core and wipe core clean. If any rust has formed on core at the handpiece end, be sure to clean thoroughly. (C) With the hand, wipe No. 514-B grease over the core sparingly. (D) Re-install casing.

Handpiece: Lubricate the handpiece also about once a month.

To remove handpiece from the shaft - (A) Push in toward shaft, twist left slightly and remove. (B) Loosen thumbscrew on guard

(Ref. No. 9 below) and remove entire guard and cutter assembly from the handpiece spindle. (C) Remove Quick-Change assembly (Ref. No. 16) from the handpiece. (D) Pull Bearing and spindle assembly out of handpiece shell. (E) Unscrew snap-on extension from hex driver and remove bearings. (F) Clean with solvent and work a small amount of Elwood Wyco No. 514-A lubricant into the bearings. (G) Re-assemble. Cutter wheels should be replaced when they become dull or worn. This makes the unit as good as new. **Caution:** Do not completely submerge handpiece in water—water could get into the bearings.

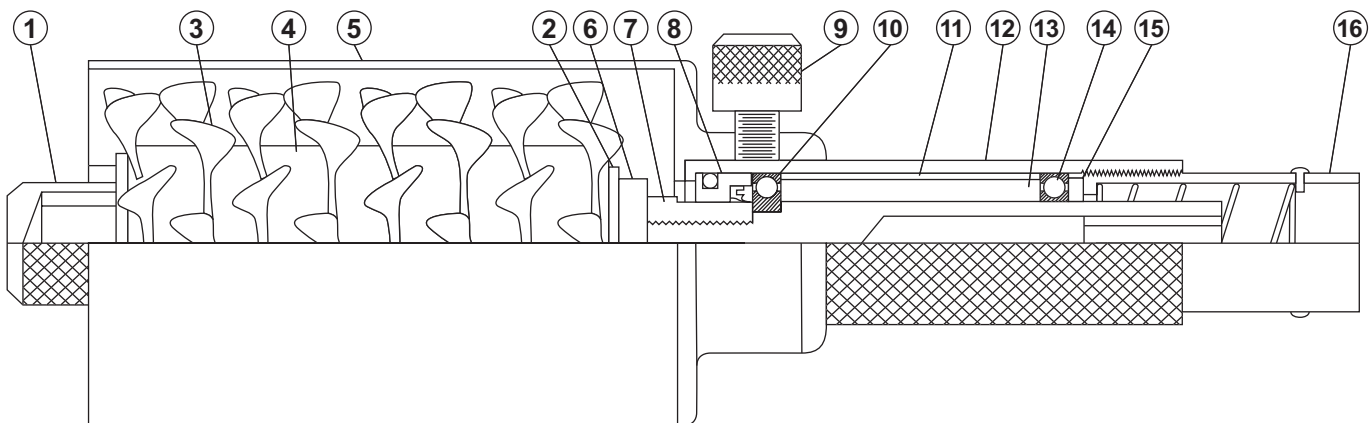

Item No.	Part No.	Qty.	Part Name
1*	432-314	1	Spec. Nut
2*	883-145	2	Washer
3*	893-140	8	Cutter Wheel
4*	783-140	7	Spacers
5	533-147	1	Safety Guard
6*	023-140	1	Scaler Wheel Arbor
7	792-030	1	Snap-On Extension
8	742-417	1	Seal Holder Assembly

Item No.	Part No.	Qty.	Part Name
9	434-614	1	Thumb Screw
10	091-031	1	Ball Bearing
11	782-280	1	Bearing Scraper
12	762-501	1	Handpiece Shell
13	382-429	1	Hex Driver
14	091-051	1	Ball Bearing
15	743-565	1	Felt Washer
16	342-218	1	Quick-Change Assembly

*These parts should be purchased as a complete assembly. (No. 341-FS)



195 W. Ryan Rd. • Oak Creek, WI 53154
 Phone: (800) 527-7500 • Fax: (414) 764-4298
 www.elwood.com

06/05
 Printed in the USA